

UNDERSTANDING THE NEEDS OF OUR CLIENTS

Leads to New Seals, Lower Costs, and Private Label Branding



A Case Study

BACKGROUND A large regional service provider maintains, retrofits, refurbishes, and distributes spare parts for street sweepers, highway maintenance vehicles and electrical service trucks. They purchase a variety of mounted bearings including a competing manufacturer's two-bolt pillow block with concentric locking collars.

THE CHALLENGE Pricing was steadily increasing each year, prompting the service provider to seek out a cost-saving solution that would also allow them to increase their own spare parts sales.

THE SOLUTION After receiving a sample, PTI consulted with the customer and redesigned the pillow blocks to the client's specifications. PTI recommended zerk extensions to allow for easier maintenance and greasing, and changed the original seal design to a nitrile rubber lip seal with a metal flinger to protect the bearing from the high amount of contaminants and wet environment common with the application. Additionally, PTI marked the housings with the service provider's name to help them generate repeat business.

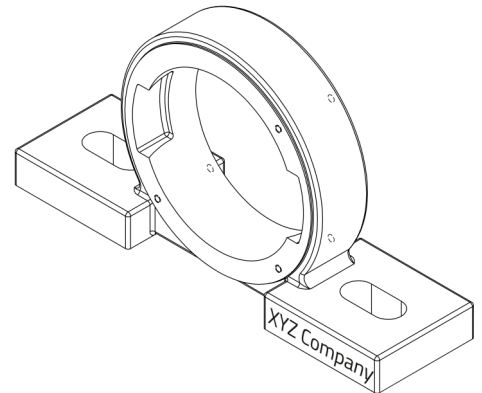

THE RESULT

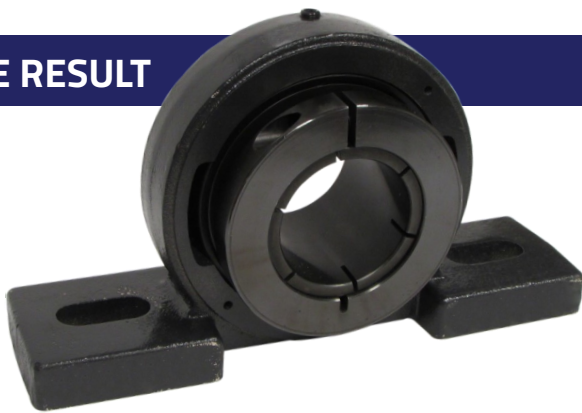

Two Bolt Pillow Block with Concentric Locking Collar

Competing Manufacturer through OEM	\$295
PTI's Solution	\$175
Savings Per Unit with PTI	\$120

The PTI solution resulted in a **40% cost savings** plus shorter lead times. The customer was very impressed with PTI's response time, flexibility, and recommendations, which led to two more custom bearing design projects.

PTI'S ABILITY PTI is committed to creating innovative and durable products for the industrial power transmission industry. Through relentless attention to detail and value-added recommendations, PTI delivers.



PTI Corporate Headquarters Charlotte, NC - USA
24/7 Inside Sales: 704-588-1091 Toll-Free: 800-763-4434
ptinfo@ptintl.com

www.ptintl.com