

# Metric Variable Pitch Pulley



**Adjustable Pitch**  
**Allows for Speed Adjustment**  
**Taper Bushing Mount**  
**Cast Iron**



**Part No. PVA108 X 1-1210**

- PV = Pulley Variable Pitch
- A, Z, B = Belt Sections
- X 1 or X 2 = Number of Grooves
- 1210 = TL Bushing Size

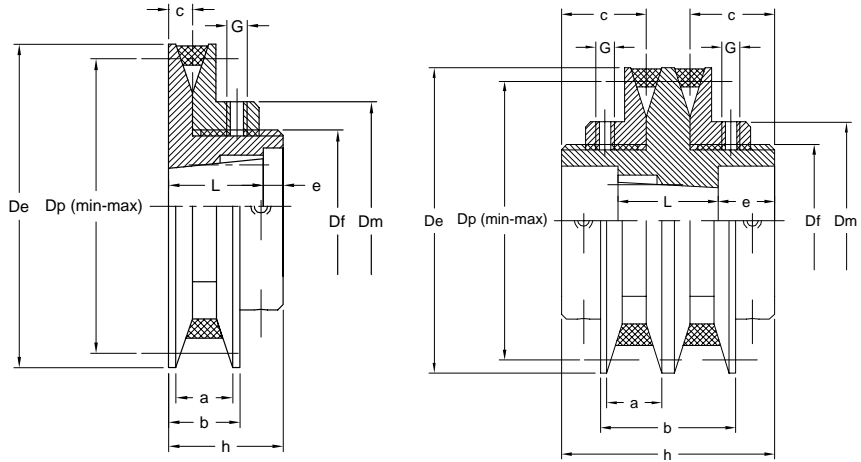

Adjustment to the pitch diameter is made by 1/4 turn of the nut and then tightening set screws on flats.

Dimensions in mm

Part No.	Belt	Bushing	Max Bore	De	Dm	Df	Dp min	Dp max	a min	a max	b min	b max	c	e	G	h	L	kg
PVZ84 x 1-1108*	Z	1108	28	84	65	50	62	80	10	14.5	15	19.5	7.5	-	6	28	28.0	0.50
PVZ95 x 1-1108	Z	1108	28	95	75	60	73	91	10	14.5	16	20.5	8.0	8.0	6	30	22.0	0.78
PVZ100 x 1-1108	Z	1108	28	100	75	60	78	96	10	14.5	16	20.5	8.0	8.0	6	30	22.0	0.85
PVZ108 x 1-1210*	Z	1210	30	108	90	72	90	104	10	14.5	16	20.5	8.0	10.0	8	35	25.0	1.13
PVA108 x 1-1210	A	1210	30	108	80	62	76	102	13	19.5	19	26.5	9.5	12.0	8	39	27.0	1.12
PVA120 x 1-1210	A	1210	30	120	91	72	88	114	13	19.5	20	26.5	10.0	10.0	8	36	26.0	1.42
PVA129 x 1-1210	A	1210	30	129	91	72	97	123	13	19.5	20	26.5	10.0	10.2	8	36	26.0	1.67
PVA139 x 1-1610	A	1610	40	139	103	85	109	133	13	18.9	20	25.9	10.0	11.0	8	37	26.0	1.96
PVA146 x 1-1610	A	1610	40	146	103	85	116	140	13	18.9	20	25.9	10.0	11.0	8	37	26.0	2.17
PVA156 x 1-1610	A	1610	40	156	103	85	126	150	13	18.9	20	25.9	10.0	11.0	8	37	26.0	2.43
PVA164 x 1-1610	A	1610	40	164	103	85	134	158	13	18.9	20	25.9	10.0	8.0	8	37	29.0	2.76
PVA177 x 1-2012	A	2012	50	177	135	110	149	171	13	18.2	20	25.2	10.0	8.0	8	40	32.0	3.76
PVA187 x 1-2012	A	2012	50	187	135	110	159	181	13	18.2	20	25.2	10.0	8.0	8	40	32.0	4.14
PVA120 x 2-1215	A	1215	30	120	91	72	88	114	13	19.5	34	47.1	26.0	12.0	8	66	40.5	2.46
PVA129 x 2-1215	A	1215	30	129	91	72	97	123	13	19.5	34	47.1	26.0	12.0	8	66	40.0	2.83
PVA139 x 2-1615	A	1615	40	139	103	85	109	133	13	18.9	35	46.8	26.0	14.5	8	69	38.5	3.37
PVA146 x 2-1615	A	1615	40	146	103	85	116	140	13	18.9	35	46.8	27.0	14.5	8	69	38.5	3.77
PVA156 x 2-1615	A	1615	40	156	103	85	126	150	13	18.9	35	46.8	27.0	14.5	8	69	38.5	4.25
PVA164 x 2-1615	A	1615	40	164	103	85	134	158	13	18.9	35	46.8	27.0	15.5	8	69	37.5	4.74
PVA177 x 2-2012	A	2012	50	177	135	110	149	171	13	18.2	35	45.5	27.5	24.0	8	90	37.0	6.80
PVA187 x 2-2012	A	2012	50	187	135	110	159	181	13	18.2	35	45.5	37.5	24.0	8	90	37.0	7.50
PVB178 x 1-2012	B	2012	50	178	135	110	139	171	16	21.5	23	28.5	10.0	8.0	8	40	32.0	3.73
PVB187 x 1-2012	B	2012	50	187	135	110	148	180	16	21.5	23	28.5	10.0	8.0	8	40	32.0	4.70
PVB178 x 2-2012	B	2012	50	178	135	110	139	171	16	22.5	42	54.5	37.5	24.0	8	90	37.0	6.75
PVB187 x 2-2012	B	2012	50	187	135	110	148	180	16	22.5	42	54.5	37.5	24.0	8	90	37.0	7.35

Note: \*Bushing mounts on opposite side from drawing.