

WINKEL Combined Bearings

Type JC Adjusting Unit For Standard Profiles

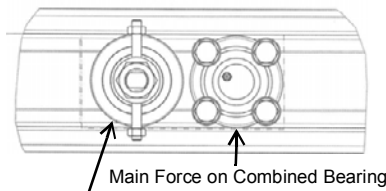

Adjustable Radial Bearing
Removes System Clearance

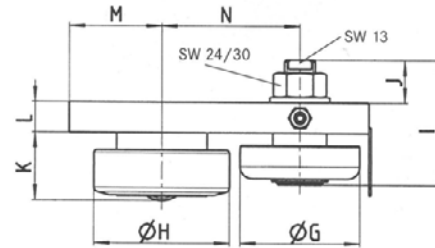
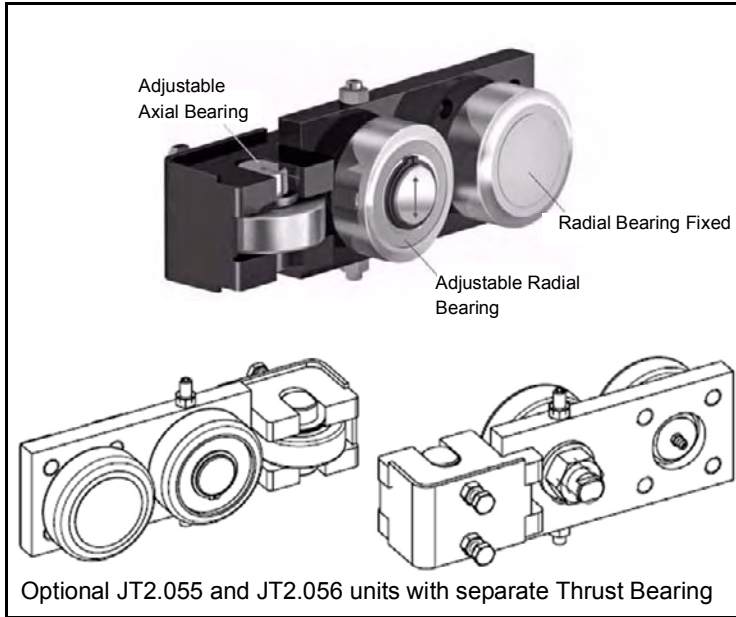
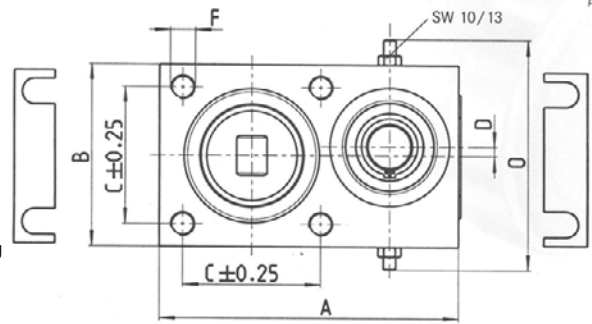

Assembly / Adjusting

- Secure the unit by the flange plate and within the profile.
- The position of the adjustable bearing must be at the opposite direction from the load.
- The main forces should be on the radial bearing of the Combined Bearing.
- The adjustable bearing can be adjusted and finally secured.
- Set adjustable bearing to the top raceway with a clearance of 0.05 to 0.10mm.

CAD Drawing Download: www.winkel.de

Bearing Part No.	Dimensions													
	A mm	B mm	C mm	+/- D mm	F mm	G mm	H mm	I mm	J mm	K mm	L mm	M mm	N mm	O mm
W-JC 4.054	140	60	40	8	M10	62.4	62.5	64	24	30.5	10	30	72.0	80
W-JC 4.055	170	80	50	10	M12	70.0	70.1	82	33	36.0	15	40	83.5	102
W-JC 4.056	170	80	50	10	M12	78.0	77.7	82	33	36.5	15	40	83.5	102
W-JC 4.058	195	120	90	20	M16	78.0	88.4	82	28	44.0	20	60	90.0	152
W-JC 4.061	240	120	80	20	M16	101.6	107.7	98	29	55.0	20	60	120.0	150
W-JC 4.062	240	120	80	20	M16	101.6	123.0	98	29	56.0	20	60	120.0	150
W-JC 4.063	265	150	100	35	M16	101.6	149.0	98	29	58.5	20	75	130.0	170

Bearing Part No.	Profile Max Static Radial Load F_{RkN}	Profile Max Static Axial Load F_{AkN}	Dynamic Load Capacity of Radial Brg C kN	Static Load Capacity of Radial Brg C_{OkN}	Dynamic Load Capacity of Axial Brg C_{AkN}	Static Load Capacity of Axial Brg C_{OaKn}	RPM max	Wt. kg	Profiles
W-JC 4.054	9.4	3.1	31.0	35.5	11	11	900	1.65	W-0Nb
W-JC 4.055	11.3	3.73	45.5	51.0	13	14	900	2.95	W-1Nb
W-JC 4.056	11.72	3.87	48.0	56.8	18	18	800	3.30	W-2Nb
W-JC 4.058	20.47	6.76	68.0	72.0	23	23	750	5.80	W-3Nb
W-JC 4.061	21.68	7.16	81.0	95.0	31	36	650	8.75	W-4Nb
W-JC 4.062	30.92	10.2	110.0	132.0	43	50	550	9.75	W-5Nb
W-JC 4.063	54.02	17.8	151.0	192.0	68	71	450	13.90	W-6Nb