

WINKEL Combined Bearings

with Oilamide Thrust Bearing with Washer

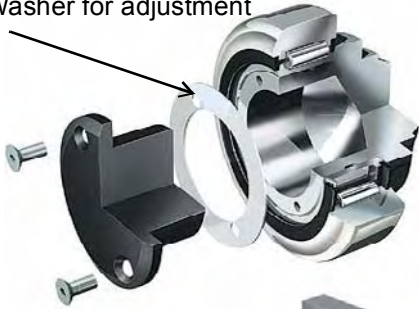

Face Washer for adjustment



The Oilamide Thrust Bearing is a high resistant self-lubricant Polyamide within a standard Cylindrical Roller bearing, ideal for thrust loads.

The adjustment of dimension (A) is obtained by means of a Face Washer positioned between the main body of the bearing and the polyamide insert. Face Washers (0.5mm and 1.0mm thickness) are available if adjustment is required.

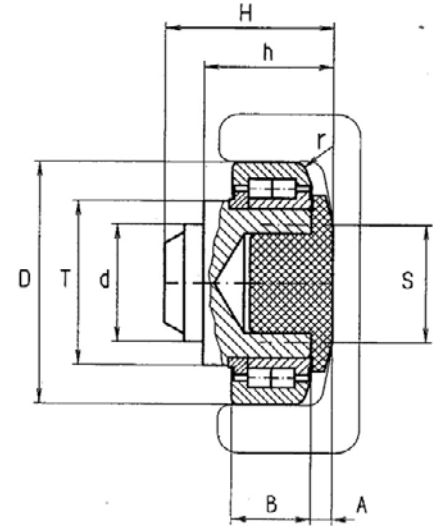

With Square Flange

With Rectangular Flange

CAD Drawing Download: www.winkel.de

Bearing only Part No.	Dimensions									Ratings					Wt. kg	Rectangular Flange Plates Part No.	Profile Part No.
	A mm	B mm	D mm	d (-0.05mm)	H mm	h mm	r mm	S mm	T mm	C kN	C ₀ kN	F _R kN	F _A kN	RPM max			
W-4.052 P	4.0	16	40	20	25	—	—	20	—	10	5.7	0.8	3.1	800	0.15	W-APA	W-A
W-4.072 P	5.5	20	62.5	30	43	33	3	25	42	31	35.5	9.4	4.0	900	0.49	W-AP0	W-0Nb
W-4.073 P	6.5	23	70.1	35	48	40	4	33	48	45.5	51	11.3	6.7	800	0.74	W-AP1	W-1Nb
W-4.074 P	7	23	78.1	40	50.5	39.5	4	40	54	48	56.8	11.7	7.2	700	0.94	W-AP2	W-2Nb
W-4.076 P	7	30	88.4	45	61	48	3	45	59	68	72	20.5	8.9	600	1.57	W-AP3	W-3Nb
W-4.0784 P	8	31	107.7	60	69	55	5	60	71	81	95	21.7	14.4	500	2.63	W-AP4	W-4Nb
W-4.079 P	8	37	123	60	75.5	59.5	5	70	80	110	132	30.9	38.4	500	3.90	W-AP4	W-5Nb
W-4.080 P	8	45	149	60	82	62	5	100	103	151	192	54.0	41.6	400	6.5	W-AP6	W-6Nb
W-4.085 P	10	57.3	180	100	99.2	79.8	5	112	124	207	243	76.0	41.6	200	11.5	W-AP90-Q	W-8Nb

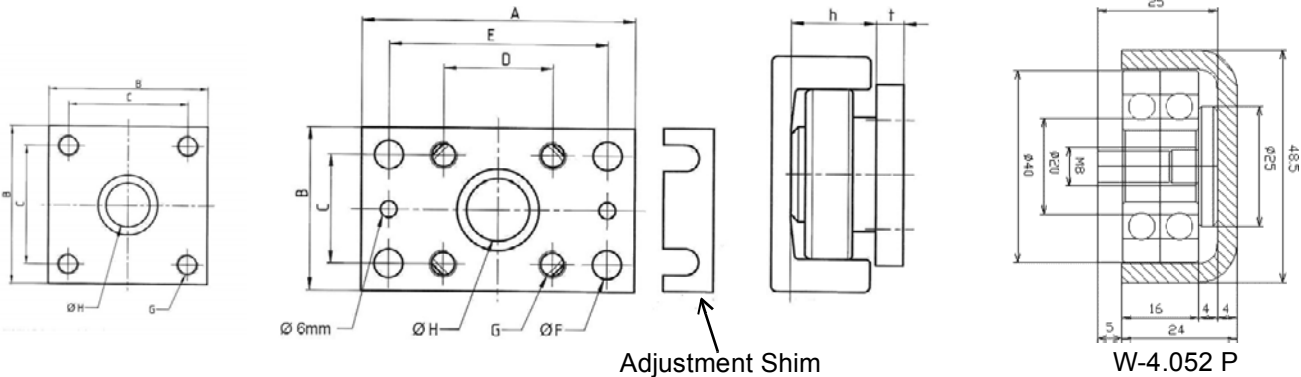

Part No. with Square Flange Plate	Part No. with Rectangular Flange Plate	Dimensions (mm)										Shim	
		A	B	C	D	E	ØF	G	ØH	h	t	t = 0.5mm	t = 1.0mm
W-4.072P/AP 0	W-4.072P/AP0-Q	100	60	40	40	80	10.50	M10	30	33	10	W-DS-0-0.5	W-DS-0-1.0
W-4.073P/AP 1	W-4.073P/AP1-Q	120	80	50	50	90	12.50	M12	35	40	15	W-DS-1-0.5	W-DS-1-1.0
W-4.074P/AP 2	W-4.074P/AP2-Q	120	80	50	50	90	12.50	M12	40	39.5	15	W-DS-2-0.5	W-DS-2-1.0
W-4.076P/AP 3.1	—	160	100	60	60	120	17.00	M16	45	48	20	W-DS-3.1-0.5	W-DS-3.1-1.0
—	W-4.076P/AP3-Q	—	120	90	—	—	—	M16	45	44.0	20	W-DS-3-0.5	W-DS-3-1.0
W-2.0784P/AP 4	W-4.0784P/AP4-Q	180	120	80	80	140	17.00	M16	60	55	20	W-DS-4-0.5	W-DS-4-1.0
W-2.079P/AP 4	W-4.079P/AP4-Q	180	120	80	80	140	17.00	M16	60	59.5	20	W-DS-4-0.5	W-DS-4-1.0
W-2.080P/AP6	W-4.080P/AP6-Q	200	150	100	100	160	17.00	M16	60	62	20	W-DS-6-0.5	W-DS-6-1.0