

## Shim Adjustable Axial Bearing



The adjustment of dimension A is obtained by means of a face washer (spacer) between the main body of the bearing and the back face of the thrust bearing surface. Face Washers 0.5mm and 1mm thick are available.

For Face Washers specify size and thickness.

Part No. W-S4.072-xx. Where xx is the Face Washer thickness of 0.5 or 1.0. Bearings are lubricated for life.

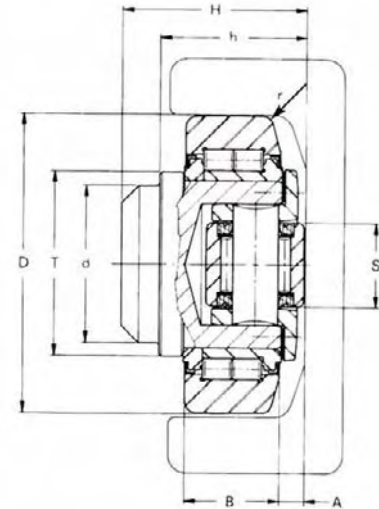



## Shim Adjustable Axial Bearing

CAD Drawing Download: [www.winkel.de](http://www.winkel.de)

Bearing only Part No.	Bearing with Rectangular Flange Plate Part No.	Bearing with Square Flange Plate Part No.	Dimensions										Brg Wt. kg	Profile Part No.
			A mm	B mm	d (-0.05mm)	D* mm	h mm	H mm	r mm	S mm	T mm	RPM max		
W-4.072	W-4.072/AP0	W-4.072/AP0-Q	5.5	20	30	62.5	33	43	3	16	42	900	0.56	W-0Nb
W-4.073	W-4.073/AP1	W-4.073/AP1-Q	6.5	23	35	70.1	40	48	4	16	48	800	0.85	W-1Nb W-3018
W-4.074	W-4.074/AP2	W-4.074/AP2-Q	7	23	40	78.1	39.5	50.5	4	21	54	700	1.02	W-2Nb
W-4.075	**	**	7	23	40	77.7	34	45	4	21	54	700	0.92	W-3019
W-4.076	W-4.076/AP3.1	W-4.076/AP3-Q	7	30	45	88.4	48	61	3	21	59	600	1.69	W-3Nb
W-4.077	**	**	7	28	50	101.2	37.5	50.5	3	21	67	600	1.85	W-2912
W-4.078	**	**	8	31	55	107.7	44.5	58.5	5	33	71	500	2.38	W-3100
W-4.0784	W-4.0784/AP4	W-4.0784/AP4-Q	8	31	60	107.7	55	69	5	33	71	500	2.80	W-4Nb
W-4.079	W-4.079/AP4	W-4.079/AP4-Q	8	37	60	123	59.5	75.5	5	33	80	500	4.08	W-5Nb W-3353
W-4.080	W-4.080/AP6	W-4.080/AP6-Q	15.0	45	60	149	69	89	5	50	103	400	6.70	W-6Nb

Note: \* OD has a slight crown to accommodate misalignments. \*\* Flange Plates available on request.

## Profile & Bearing Load Ratings

Bearing only Part No.	Profile		Dynamic Load Capacity of Radial Brg C kN	Static Load Capacity of Radial Brg C <sub>0</sub> kN	Dynamic Load Capacity of Axial Brg C <sub>A</sub> kN	Static Load Capacity of Axial Brg C <sub>0A</sub> kN
	C-Profile	I-Profile				
						
W-4.072	0 Nb	—	31.0	35.5	8	8
W-4.073	1 Nb	3018	45.5	51.0	14	14
W-4.074	2 Nb	—	48.0	56.8	14	14
W-4.075	—	3019	48.0	56.8	14	14
W-4.076	3 Nb	3020	68.0	72.0	15	15
W-4.077	—	2912	73.0	82.0	18	19
W-4.078	—	3100	81.0	95.0	31	36
W-4.0784	4 Nb	—	81.0	95.0	31	36
W-4.079	5 Nb	3353	110.0	132.0	35	38
W-4.080	6 Nb	—	151.0	192.0	68	71

# WINKEL Combined Bearings

## Shim Adjustable Axial Bearing



### Rectangular Flange Plate

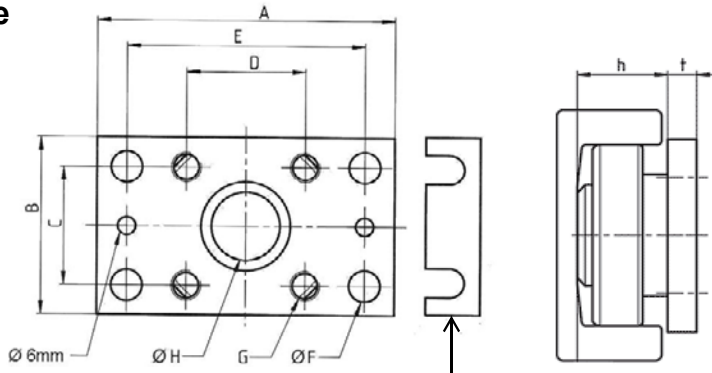
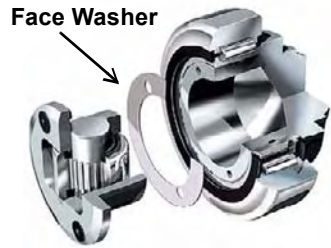

### Square Flange Plate

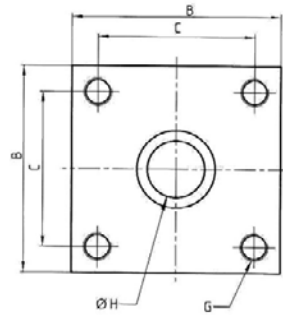

### Adjustment Shim

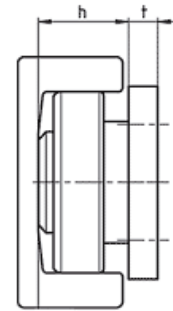

### Clamp Flange



### Flange Plate Detail

Bearing with Rectangular Flange Plate Part No.	Bearing with Square Flange Plate Part No.	Dimensions										Flange Plate Only	
		A mm	B mm	C mm	D mm	E mm	ØF mm	G	ØH mm	h mm	t mm	Rectangular Part No.	Square Part No.
W-4.072/AP0	W-4.072/AP0-Q	100	60	40	40	80	10.5	M10	30	30.5	10	W-AP0	W-AP0-Q
W-4.073/AP1	W-4.073/AP1-Q	120	80	50	50	90	12.5	M12	35	36.0	15	W-AP1	W-AP1-Q
W-4.074/AP2	W-4.074/AP2-Q	120	80	50	50	90	12.5	M12	40	36.5	15	W-AP2	W-AP2-Q
W-4.076/AP3.1	—	160	100	60	60	120	17.0	M16	45	44.0	20	W-AP3.1	—
—	W-4.076/AP3-Q	—	120	90	—	—	—	M16	45	44.0	20	—	W-AP3-Q
W-4.0784/AP4	W-4.0784/AP4-Q	180	120	80	80	140	17.0	M16	60	55.0	20	W-AP4	W-AP4-Q
W-4.079/AP4	W-4.079/AP4-Q	180	120	80	80	140	17.0	M16	60	56.0	20	W-AP4	W-AP4-Q
W-4.080/AP6	W-4.080/AP6-Q	200	150	100	100	160	17.0	M16	60	58.5	20	W-AP6	W-AP6-Q

### Adjustment Shims for Flange Bearings

Bearing Size	0.5 mm Shim Part No.	1.0 mm Shim Part No.	Face Washer 0.5 mm Part No.	Face Washer 1.0 mm Part No.
W-4.072	W-DS-0-0.5	W-DS-0-1.0	W-S-4.072-0.5	W-S-4.072-1.0
W-4.073	W-DS-1-0.5	W-DS-1-1.0	W-S-4.073-0.5	W-S-4.073-1.0
W-4.074	W-DS-2-0.5	W-DS-2-1.0	W-S-4.074-0.5	W-S-4.074-1.0
W-4.076	W-DS-3-0.5	W-DS-3-1.0	W-S-4.076-0.5	W-S-4.076-1.0
W-4.0784	W-DS-4-0.5	W-DS-4-1.0	W-S-4.0784-0.5	W-S-4.0784-1.0
W-4.079	W-DS-4-0.5	W-DS-4-1.0	W-S-4.079-0.5	W-S-4.079-1.0
W-4.080	W-DS-6-0.5	W-DS-6-1.0	W-S-4.080-0.5	W-S-4.080-1.0

### Clamp Flanges for Mounting Profile

Part No.	Profile Size
W-KF 0	0Nb
W-KF 1	1Nb
W-KF 2	2Nb
W-KF 3	3Nb
W-KF 4	4Nb

See Clamp Flange page for Dimensions.