

Flanged Housings

722500 Series - 3 Bolt Triangular

For 1200, 2200 & 222 Series Bearings

These Flanged Housings accommodate 1220, 2200 series Ball and 222 series Spherical Bearings. Type A housings are closed one end, and Type B are open on both ends. Both are supplied with seals and fixing rings. For expansion units omit the fixing ring. Specify Type A or B when ordering. Units are normal stock.

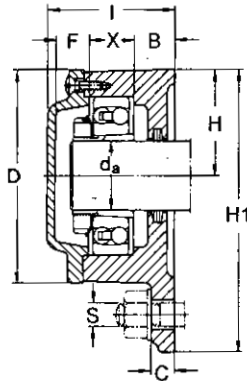

Type A - Closed End

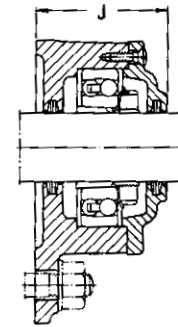
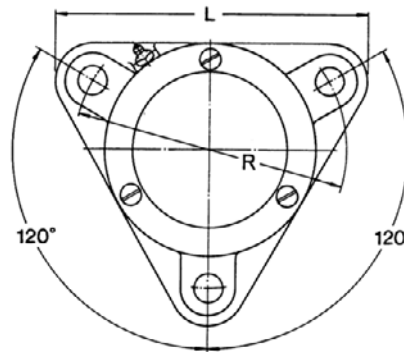

Type B - Open End

Part No. Closed End	Part No. Open End	Bore d_a	Dimensions (mm)											Wt. kg	
			B	C	D	F	H	H ₁	I	J	L	R	S		X
722505DA	722505DB	20	15	10	75	12.5	38.0	100	51.5	56.5	110	96	10	20	1.1
722506DA	722506DB	25	16	12	86	15.0	44.0	117	57.0	59.5	130	116	10	22	1.5
722507DA	722507DB	30	16	12	97	14.5	48.5	130	59.5	63.5	145	130	12	25	1.8
722508DA	722508DB	35	17	12	108	18.0	54.0	143	64.0	65.5	160	140	12	25	2.3
722509DA	722509DB	40	19	12	113	16.5	60.0	160	64.5	69.5	180	160	12	25	3.0
722510DA	722510DB	45	22	15	118	17.5	60.0	160	68.5	73.0	180	160	12	25	3.5
722511DA	722511DB	50	24	15	128	19.5	65.0	172	75.5	81.5	192	170	12	27	4.1
722512DA	722512DB	55	23	15	142	19.0	72.0	189	77.0	82.0	210	180	12	30	4.8
722513DA	722513DB	60	22	15	152	20.0	78.0	203	80.0	86.0	225	190	12	33	5.9

Bearings, Sleeves and Accessories

Size Part No.	Bearing Part No.	Basic Dynamic Rating C kN	Sleeve Part No.	Fixing Ring Part No.	Seals Part No.
722505D	1205K	12.2	H205	FR5 x 52	FS120
	2205K	17.0	H305	ZW42 x 52	
	22205K	35.0	H305	ZW42 x 52	
722506D	1206K	15.6	H206	FR6 x 62	FS120
	2206K	25.5	H306	ZW50 x 62	
	22206K	48.0	H306	ZW50 x 62	
722507D	1207K	16.0	H207	FR8 x 72	FS130
	2207K	32.0	H307	ZW65 x 72	
	22207K	67.0	H307	ZW65 x 72	
722508D	1208K	19.3	H208	FR7 x 80	FS130
	2208K	31.5	H308	ZW70 x 80	
	22208K	73.0	H308	ZW70 x 80	
722509D	1209K	22.0	H209	FR6 x 85	FS150
	2209K	28.0	H309	ZW75 x 85	
	22209K	77.0	H309	ZW75 x 85	

Size Part No.	Bearing Part No.	Basic Dynamic Rating C kN	Sleeve Part No.	Fixing Ring Part No.	Seals Part No.
722510D	1210K	22.8	H210	FR5 x 90	FS165
	2210K	28.0	H310	ZW80 x 90	
	22210K	84.0	H310	ZW80 x 90	
722511D	1211K	27.0	H211	FR6 x 100	FS200
	2211K	39.0	H311	ZW85 x 100	
	22211K	115.0	H311	ZW85 x 100	
722512D	1212K	30.0	H212	FR8 x 110	FS200
	2212K	47.5	H312	ZW90 x 110	
	22212K	122.0	H312	ZW90 x 110	
722513D	1213K	31.0	H213	FR10 x 120	FS210
	2213K	57.0	H313	ZW100 x 120	
	22213K	148.0	H313	ZW100 x 120	

Flanged Housings



722500 Series - 4 Bolt Flange

For 1200, 2200, & 222 Series Bearings

These 722500 Series Flange Housings utilize self aligning Ball or Spherical Roller Bearings. Type A housings are closed end, Type B are open on both ends. Seals and fixing rings are included. For expansion units omit the fixing ring. Specify Type A or B when ordering. Units are normal stock.

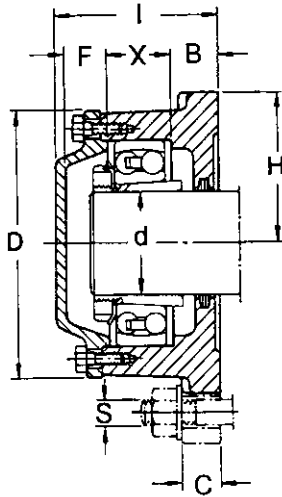

Type A - Closed End

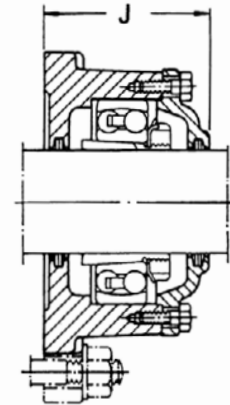
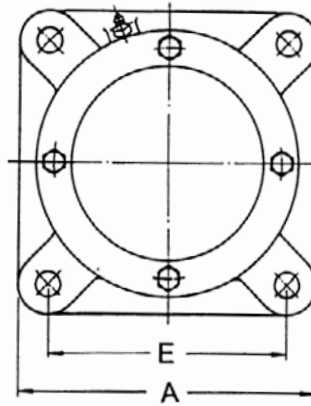

Type B - Open End

Part No. Closed End	Part No. Open End	Bore d	Dimensions (mm)											Wt. kg
			A	B	C	D	E	F	H	I	J	S	X	
722515A	722515B	65	190	30	25	168	152	27	95	104	104	16	41	9.4
722516A	722516B	70	196	31	25	176	152	30	98	110	110	16	43	10.0
722517A	722517B	75	210	31	25	188	170	30	105	114	114	16	46	11.5
722518A	722518B	80	210	30	25	198	170	31	105	118	118	16	50	12.5
722520A	722520B	90	250	30	30	224	198	33	125	127	127	20	56	18.0
722522A	722522B	100	270	30	30	246	219	38	135	137	137	20	63	22.0

Bearings, Sleeves and Accessories

Size Part No.	Bearing Part No.	Basic Dynamic Rating C kN	Sleeve Part No.	Fixing Ring		Seals Part No.
				Qty	Part No.	
722515	1215K	39.0	H215	2	FR 8 x 130	FS260
	2215K	44.0	H315	1	FR 10 x 130	
	22215K	156.0	H315	1	FR 10 x 130	
722516	1216K	40.0	H216	2	FR 8.5 x 10	FS330
	2216K	51.0	H316	1	FR 10 x 140	
	22216K	175.0	H316	1	FR 10 x 140	
722517	1217K	48.0	H217	2	FR 9 x 150	FS330
	2217K	58.5	H317	1	FR 10 x 150	
	22217K	210.0	H317	1	FR 10 x 150	

Size Part No.	Bearing Part No.	Basic Dynamic Rating C kN	Sleeve Part No.	Fixing Ring		Seals Part No.
				Qty	Part No.	
722518	1218K	57.0	H218	2	FR 10 x 160	FS350
	2218K	71.0	H318	1	FR 10 x 160	
	22218K	250.0	H318	1	FR 10 x 160	
722520	1220K	69.5	H220	1	FR 10 x 180 and FR 12 x 180	FS370
				1	FR 10 x 180	
	22220K	98.0	H320	1	FR 10 x 180	
722522	1222K	88.0	H222	2	FR 12.5 x 200	FS460
	2222K	124.0	H322	1	FR 10 x 200	
	22222K	405.0	H322	1	FR 10 x 200	