

WINKEL Combined Bearings

Radial Bearing

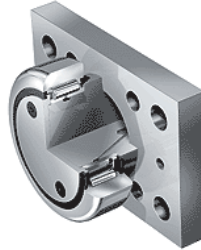

With Square Flange



With Rectangular Flange

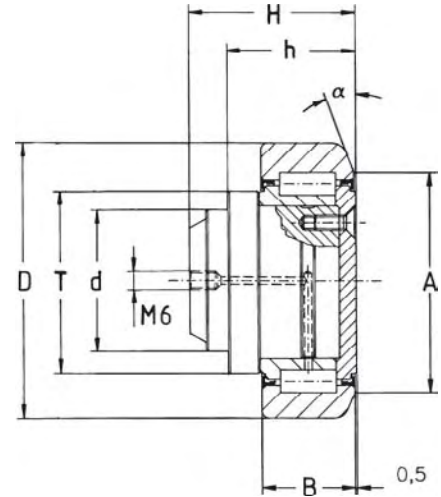

W-2.054 thru W-2.063 can be relubricated

Bearing only Part No.	Bearing with Rectangular Flange Part No.	Bearing with Square Flange Part No.	Dimensions								Ratings				Wt. kg	Flange Plates Part No. *	Profile Part No.
			A mm	α deg	B mm	D mm	d (-0.05mm)	H mm	h mm	T mm	C kN	C ₀ kN	F _R kN	RPM max			
W-2.054	W-2.054/AP0	W-2.054/AP0-Q	50	20°	20	62.5	30	36.5	28.5	42	31	35.5	9.4	900	0.55	W-AP0	W-0Nb
W-2.055	W-2.055/AP1	W-2.055/AP1-Q	57	20°	23	70.1	35	42	34	48	45.5	51	11.3	900	0.80	W-AP1	W-1Nb
W-2.056	W-2.056/AP2	W-2.056/AP2-Q	61	20°	23	77.7	40	45.5	34	53	48	56.8	11.7	800	1.05	W-AP2	W-2Nb
W-2.058	W-2.058/AP3.1	W-2.058/AP3-Q	68	20°	30	88.4	45	54	41	59	68	72	20.5	750	1.70	W-AP3.1	W-3Nb
W-2.061	W-2.061/AP4	W-2.061/AP4-Q	82	20°	31	107.7	60	65.5	51.5	71	81	95	21.7	650	2.90	W-AP4	W-4Nb
W-2.062	W-2.062/AP4	W-2.062/AP4-Q	92	20°	37	123	60	67.8	51.5	80	110	132	30.9	550	4.00	W-AP4	W-5Nb
W-2.063	W-2.063/AP6	W-2.063/AP6-Q	116	15°	45	149	60	74	54	103	151	192	54.0	450	6.70	W-AP6	W-6Nb

Note: *For Square Flange Plate, add -Q to the part no.

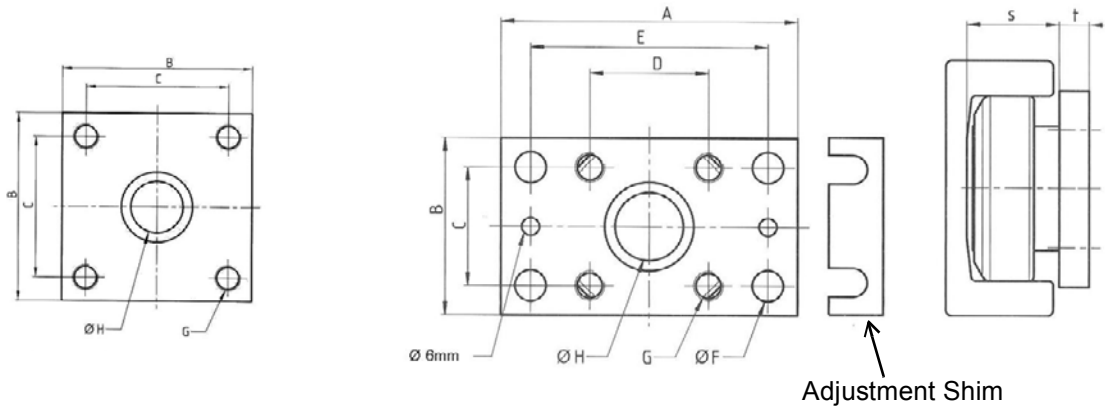

Part No. with Rectangular Flange Plate	Part No. with Square Flange Plate	Dimensions (mm)										Shim t = 0.5mm	Shim t = 1.0mm
		A	B	C	D	E	ØF	G	ØH	s	t		
W-2.054/AP0	W-2.054/AP0-Q	100	60	40	40	80	10.5	M10	30	30.5	10	W-DS-0-0.5	W-DS-0-1.0
W-2.055/AP1	W-2.055/AP1-Q	120	80	50	50	90	12.5	M12	35	36	15	W-DS-1-0.5	W-DS-1-1.0
W-2.056/AP2	W-2.056/AP2-Q	120	80	50	50	90	12.5	M12	40	36.5	15	W-DS-2-0.5	W-DS-2-1.0
W-2.058/AP3.1	—	160	100	60	60	120	17.0	M16	45	44	20	W-DS-3.1-0.5	W-DS-3.1-1.0
—	W-4.058/AP3-Q	—	120	90	—	—	—	M16	45	44	20	W-DS-3-0.5	W-DS-3-1.0
W-2.061/AP4	W-2.061/AP4-Q	180	120	80	80	140	17.0	M16	60	56	20	W-DS-4-0.5	W-DS-4-1.0
W-2.062/AP6	W-2.062/AP6-Q	200	150	100	100	160	17.0	M16	60	58.5	20	W-DS-6-0.5	W-DS-6-1.0
W-2.063/AP4	W-2.063/AP4-Q	180	120	80	80	140	17.00	M16	60	56	20	W-DS-4-0.5	W-DS-4-1.0

CAD Drawing Download: www.winkel.de