

Eich Spring Wound Bearings



Assembly instructions



Assembly tools

The Eich system of spring bush bearings simplifies installation. Special positioning at the shaft or the bore is not necessary. In general bearing tolerances are aligned to h7/H7 —other fits can be adjusted without problems.

The 'mounting principle' of pre-load results from the chosen diameter for inner and outer spring bush ring: unmounted, the inner spring bush diameter is smaller than the shaft diameter; and again unmounted the outer spring bushing's diameter is bigger compared to the bore diameter.

Before installation check the mentioned diameter ratio of inner ring to shaft and outer ring to bore.

Installation of the inner spring bush. Two hook wrenches aid the installation of the inner spring bush. Place the wrenches at the two opposite ends of the inner spring bush and turn them in opposite directions, thus enlarging the diameter. Opened like this the spring bush can easily be positioned on the shaft. After releasing the hook wrenches, press the windings of the bushes in axial directions, tapping the bushing gently with a piece of hard wood or a copper hammer.

Note: Never force the spring bushes axially —by using a shaft nut or anything similar!



1. Adjust the hook wrenches at both ends of the bushes

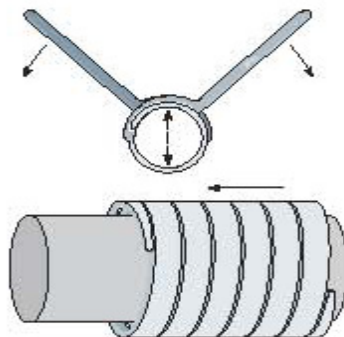

2. Enlarge the diameter by turning the wrenches in opposite directions

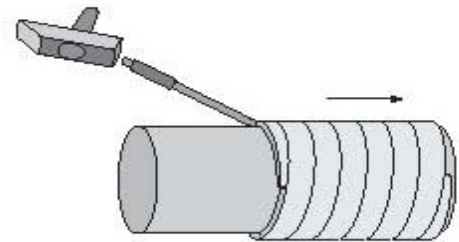

3. Release the wrenches and use a copper hammer to telescope the spring bush

Installation of the outer spring bush. The outer spring bush is installed using a lever. The nut in the lever corresponds to the wall thickness of the outer spring bush.

Hold the outer spring bush at an angle against the bore, so that the start of the winding fits into the bore. Using the lever, turn the outer spring bush in a clockwise direction and push it into the bore.

Analogical to the installation of the inner spring bushing, tap the windings of the bushes together gently in an axial direction.

Note: Never load the spring bushings axially by screwing on a housing cover or any similar method.

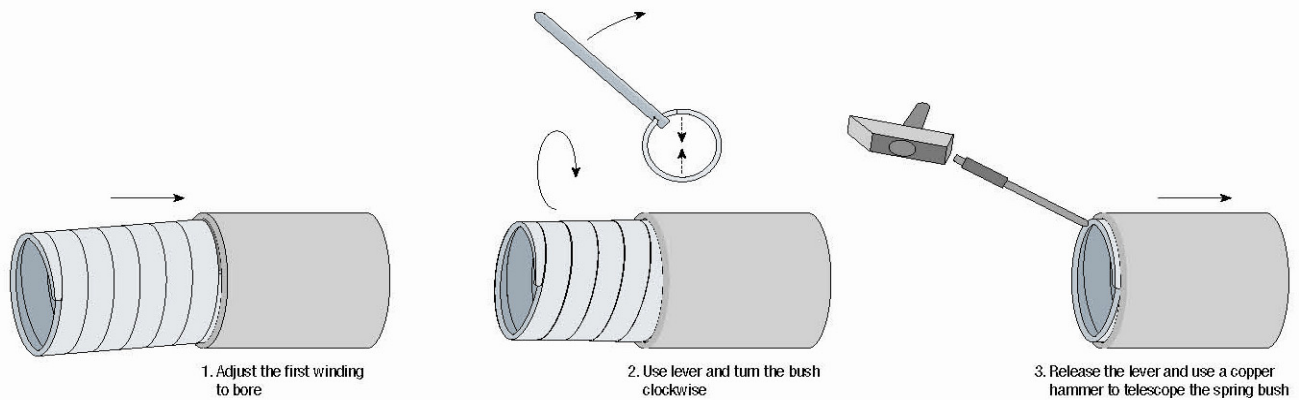

Fit-up aid for roller cages. In the case of bearings ID > 250 mm or problematic locations it might occur that the rollers cant at the respective rings (OR/IR). To aid installation use appropriate rings as lead-in chamfer or bevel. The conical ring helps to center the rollers and the roller cage is then placed easily between inner and outer ring of the spring bush bearing.

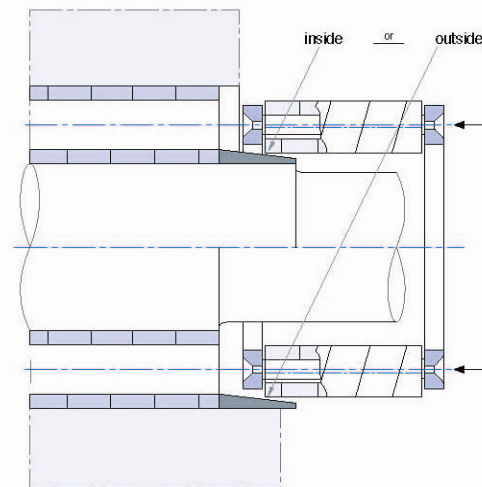

P.T. International Corp.

1817 Westinghouse Blvd.
P.O. Box 411244 (28241)
Charlotte, NC 28273
Ph: 704-588-1091
Fax: 704-588-5738
www.ptintl.com
E-mail: info@ptintl.com